

Gooch & Housego



VHE

Acousto-Optic Q-Switch

The VHE (Very High Efficiency) acousto-optic Q-Switch is ideal for use in high gain, high power, **linearly polarised** Nd:YAG & NdYVO₄ lasers. Using a unique patented acousto-optic design, it provides up to 96% single pass loss modulation, compared to ~85% for conventional designs.

Utilising our 'Stallion' manufacturing technique providing superior corrosion resistance whilst maintaining optimum performance and RF power handling capabilities up to 100W.

In addition to the standard product shown, custom configurations are available for specialised applications. These include alternative housing options and custom wavelengths.

Our scientists and engineers are available to assist in selecting the most appropriate model of Q-Switch and also RF driver for your application.

Please contact the sales team for further information.

Key Features:

- Exceptional loss modulation
- Superior corrosion resistance
- Stainless steel cooling channels
- High damage threshold
- Push fit water-connectors
- Up to 100W RF power handling
- Custom configurations available

Application examples:

- Material processing:
 - Marking
 - Engraving
 - Scribing
 - Surface treatment



info@amstechnologies.com
www.amstechnologies-webshop.com



Contact: sales@goochandhousego.com

www.goochandhousego.com

As part of our policy of continuous product improvement we reserve the right to change specifications at any time
IWDS004 V1.0

General Specifications

Interaction material:	Crystal Quartz
Wavelength:	1064nm
AR coating reflectivity:	< 0.2% per surface
Damage threshold:	> 1GWcm ⁻²
Transmission (single pass):	> 99.6%
RF Frequency:	68MHz
VSWR:	< 1.2:1 (50Ω input impedance)
RF power rating:	100W cw (max)
Loss Modulation:	> 95% (single pass)
Water flow rate:	> 190cc / minute
Water-cooling channel material:	Stainless steel 316
Recommended water temperature:	+22°C to +32°C
Thermal switch cut-off:	+65°C +/- 5°C
Storage temperature:	-20 to +70degC

Ordering Codes

Example: I-QS068-2.5V10G-N5-ST3 (Q-Switch, 68MHz, 2.5mm active aperture, VHE, Crystal Quartz, 1064nm, 4mm OD straight push fit water-connectors, BNC, Stallion housing with M3 mounting holes)

I - Q S 0 6 8 - X X X V 1 0 G - X 5 - S T 3

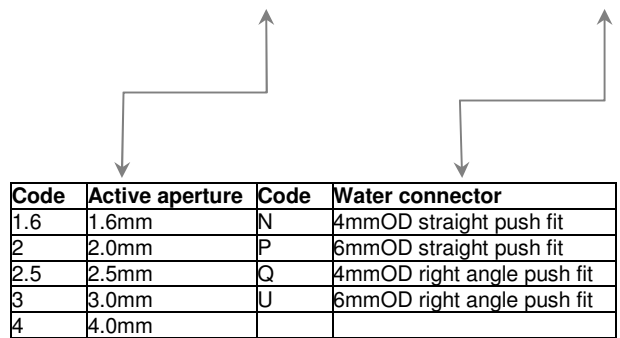

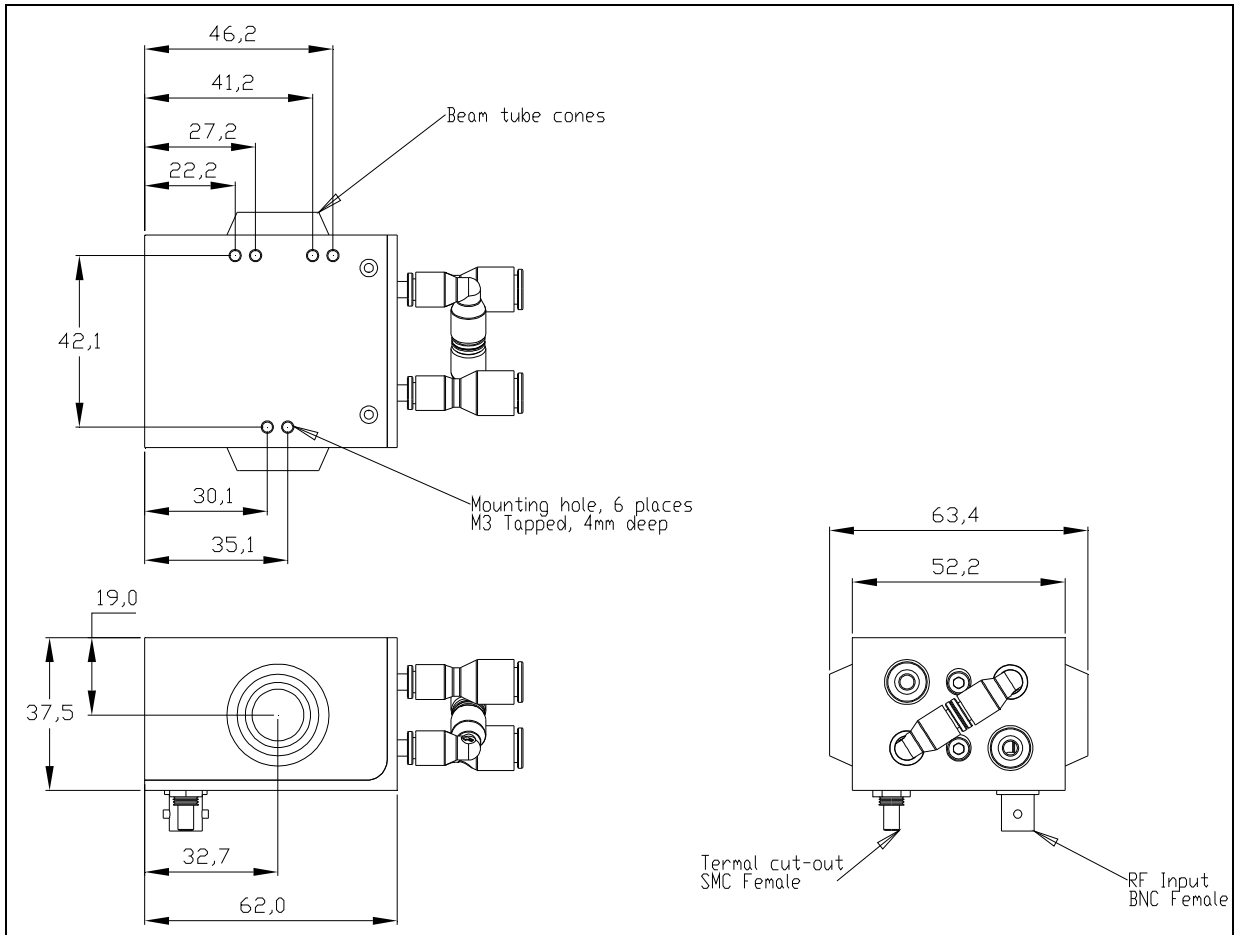

amSTECHNOLOGIES
where technologies meet solutions

info@amstechnologies.com
www.amstechnologies-webshop.com

Contact us 

Contact: sales@goochandhousego.com

www.goochandhousego.com

As part of our policy of continuous product improvement we reserve the right to change specifications at any time