

Gooch & Housego



**High Power RF Driver:
For Acousto-optic Q-Switch**

MQH0XX-YYDM-ZZZ

Former Model Number:

390XX-YYDMZZZ-A

Description:

The **MQH0XX-YYDM-ZZZ** module is a High Power RF Driver, designed to drive a Q-Switch. The driver has two digital modulation inputs: Fixed and Variable. These controls allow the customer to issue a pulse command of a "Fixed" pulse width, the duration determined by the Driver's pulse width control, settable by the customer, or issue a "Variable" pulse command, the duration determined by the input signal's pulse width. The output power is controlled by the analog input, where the mode of operation is defined by ZZZ = A05 normal analog mode, or R05 analog switched to full RF mode or a triggered RF Ramp Down mode where ZZZ = FPS first pulse suppression mode or PPK pre-pulse kill mode. The choices of Frequency (XX), Output Power (YY), and Power Control (ZZZ) option are "Factory Set" when ordered. The RF Driver requires forced air cooling.

The product delivered will be manufactured to be compliant with EU Directive 2011/65/EU for Reduction of Hazardous Substance. The product will be manufactured to other standards upon customer request.

Key Features:

- 24, 27.12, 40.68, 68, or 80 MHz RF Frequency (XX)
- 0.01% Quartz Stabilized
- Up to 100* watts RF power output (YY)
- Two TTL Digital Modulation Inputs: fixed and variable pulse width.
- Analogue Modulation or Triggered RF Ramp Down Mode (ZZZ)
- Up to 100 kHz Pulse Rate.
- Fault Protection on Low Power, High Power, and High VSWR
- Operates on 28 VDC

Applications:

- RF Driver for an Acousto-Optic Q-Switch Device used to spoil the "Q" of a CW laser so as to output an intense pulse of light.
- Used in industrial, medical, or military applications.



MQH0XX-YYDM-ZZZ

SPECIFICATIONS:

PARAMETER	SPECIFICATION
Output Frequency is " <u>Factory Set When Ordered</u> ":	XX = 24, 27, 41, 68, or 80
RF Frequency:	24.00, 27.12, 40.68, 68.00, 80.00 MHz \pm 0.01%
Spurious Levels:	-50 dBc maximum
Harmonic Distortion	-30 dBc maximum
Digital Inputs:	TTL Levels, Triggered on Rising Edge. Pulse Width Applied >50 ns.
Fixed Mod In	TTL Levels, TTL High = RF off
Variable Mod In	
Extinction Ratio:	35 dB minimum
RF Rise Time 10% to 90%	500 ns maximum
RF Fall Time: 90% to 10%	100 ns maximum
Modulation Repetition Rates:	1 Hz to 100 kHz for Fixed Modulation DC to 100 kHz for Variable Modulation
Fixed Modulation Output Pulse Width Adjustment Range:	1 to 14 μ s, Customer Adjustable
Available Pulse Control Options:	ZZZ = Mode
Pulse Control Mode is " <u>Factory Set When Ordered</u> ":	FPS = First Pulse Suppression See Figure 2 PPK = Pre Pulse Kill See Figure 3 A05 = Analog Control See Figure 4 R05 = RF Switched to Analog Control See Figure 5 ___ = Digital Modulation Only See Figure 6
FPS Trigger / Analog input	Units configured with FPS, PPK: TTL Levels, Triggered on TTL Rising Edge. Units configured with A05, R05: 0 to 5 volts analog.
*RF Output Power " <u>Factory Set When Ordered</u> ":	YY = 50 or 100 watts nominal for 24, 27, 41, and 68 MHz units Adjustable from 25 to 100 watts. 50 watts nominal for 80 MHz units, Adjustable from 20 to 50 watts.
Output Impedance:	50 ohms nominal
Shutter Output:	0.3 sec delay. Opens on fault. Capable of sinking 1 amp at 28 volts Maximum.
Supply Voltage Input	+28 VDC \pm 1%
Supply Current Input	6.5 A for 50 W units 9.0 A for 100 W units
Operating Temperature	+10°C to +55°C
Air Flow through Heat Sink	> 36 CFM (> 17 litres / second) @ 25°C
<u>MAXIMUM RATINGS:</u>	
Supply Voltage:	30 volts DC maximum
Power Output:	No DC Feedback Allowed
Storage Temperature:	-20°C to +85°C

CONNECTORS & MECHANICAL:

RF Output Connector:

Located on front panel

BNC Female

Power Supply Connections:

Vcc Solder Post
Return Ground Lug

25PIN D-SUB CONNECTOR PINOUT:

Located on front panel. See Detail A of Outline Drawing.

1	+5V	+5V output for external fault indicators, 75 mA available.
2 – 3	NC	No connection.
4	THERM RTN	Ground – to be used as a return for THERM.
5	NC	No connection.
6	THERM	Thermostat connection – driver enters a fault condition unless this is Shorted to ground.
7	DRV TEMP	Normally HIGH, goes LOW when the driver is in an overheat fault.
8	QS TEMP	Normally HIGH, goes LOW when no short present on THERM.
9	HVSWR	High VSWR fault, normally HIGH, goes LOW during fault.
10	LP	Low RF Power indicator, normally HIGH, goes LOW while driver output is below the Low RF Power threshold.
11	HP	High RF Power fault, normally HIGH, goes LOW during fault.
12	MOD IN ANALOG	Controls the output power level in A05 and R05 models
13	FAULT RESET	Pulse LOW to reset the driver from a fault condition. This line should not be held LOW or it will defeat some of the fault conditions.
14	FPS TRG	Triggers a suppression pulse on a RISING edge.
15	MOD IN FIXED	Turns the driver off for the duration set by the pulse width control.
16	MOD IN VARIABLE	Turns the driver off while this input is HIGH.
17	SYNC OUT	Outputs a signal synchronized to the modulation output.
18-19	NC	No connection.
20	SHUTTER	0.3 sec delay. Opens on fault. Capable of sinking 1 amps at 28 volts maximum.
21 -24	NC	No Connection
25	GND	Ground.

Note: Some Control Signals Shown on Outline Drawing are Not Available on Standard Units.

INDICATORS:

Located on front panel

Power	Power Indicator – The module has 28V applied on the DC connector.
Low Power	Faults after 0.3 second, power below LP Set Point. Resets on power adjusted above Set Point.
High Power	Faults when power above HP Set Point. Reset required after removing fault.
High VSWR	Faults when reflected power above VSWR Set Point. Reset required after removing fault.
QS Temp	Faults on open Thermostat. Resets on closed Thermostat. (Q-Switch below set temperature)
DRV Temp Driver	The internal temperature of the module has reached 60°C. The driver will remain in this fault condition until it cools down.

ADJUSTMENTS:

Located Inside Unit Through Holes in Module Top Cover

RF Power Level Adjustment	Adjusts the output RF Power.
LP Set Point	Adjusts the minimum power threshold. If the module's output goes below this set value, the low power warning light will turn on, but the driver will continue to output power. This is a warning, not a true fault condition.
HP Set Point	Adjusts the maximum power threshold for the module. If the output rises above this threshold, the module will cease output until it is reset.
VSWR Set Point	Adjusts the module's tolerance for a mismatched load connected to RF Out. If a mismatch is detected, the driver will cease outputting power until reset.
Pulse Width	Adjusts the length of time the driver outputs no RF energy after receiving a trigger. 1 μ s to 14 μ s.

The following adjustment is not used on units configured with FPS or PPK:

Threshold	Sets the point below which the analog voltage is ignored and the system output is shut off.
-----------	---

The following adjustments are not used on units configured with Analog Input (A05, R05):

FPS Start	Adjusts the initial power level of the first pulse.
FPS Slope	Adjusts how quickly the RF pulses return to their normal level after the FPS has been triggered. 20 μ s to 300 μ s.
FPS Window	Adjusts the duration of the suppression pulse cycle. 20 μ s to 300 μ s.

Note: Some Adjustments Shown on Outline Drawing are Not Available on Standard Units.

Mechanical Dimensions:

Dimensions in inches and [mm]

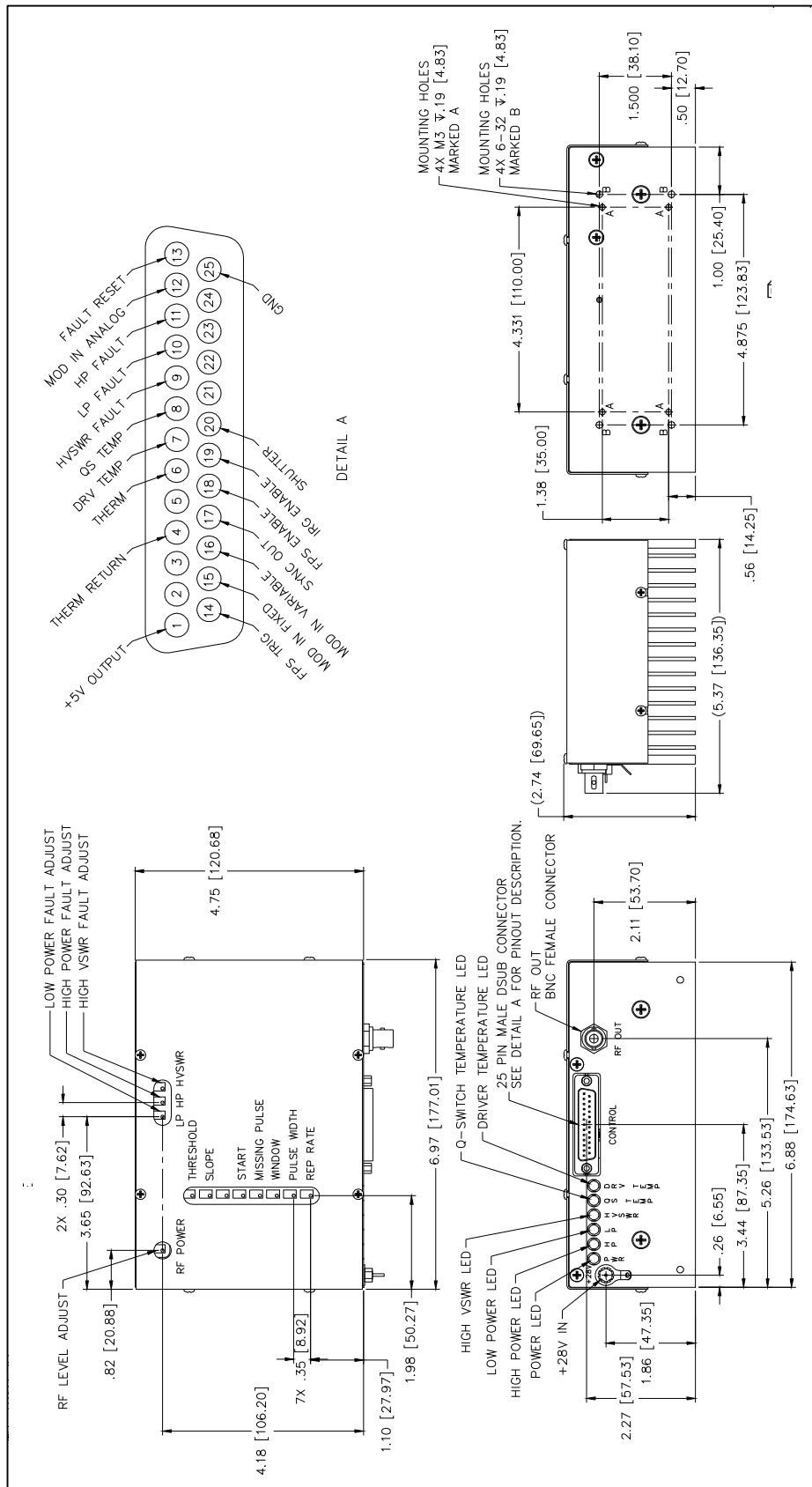

Control Diagrams

Figure 2

MQH0XX-YYDM-FPS (HIGH POWER) First Pulse Suppression Control Connection and Control Diagrams

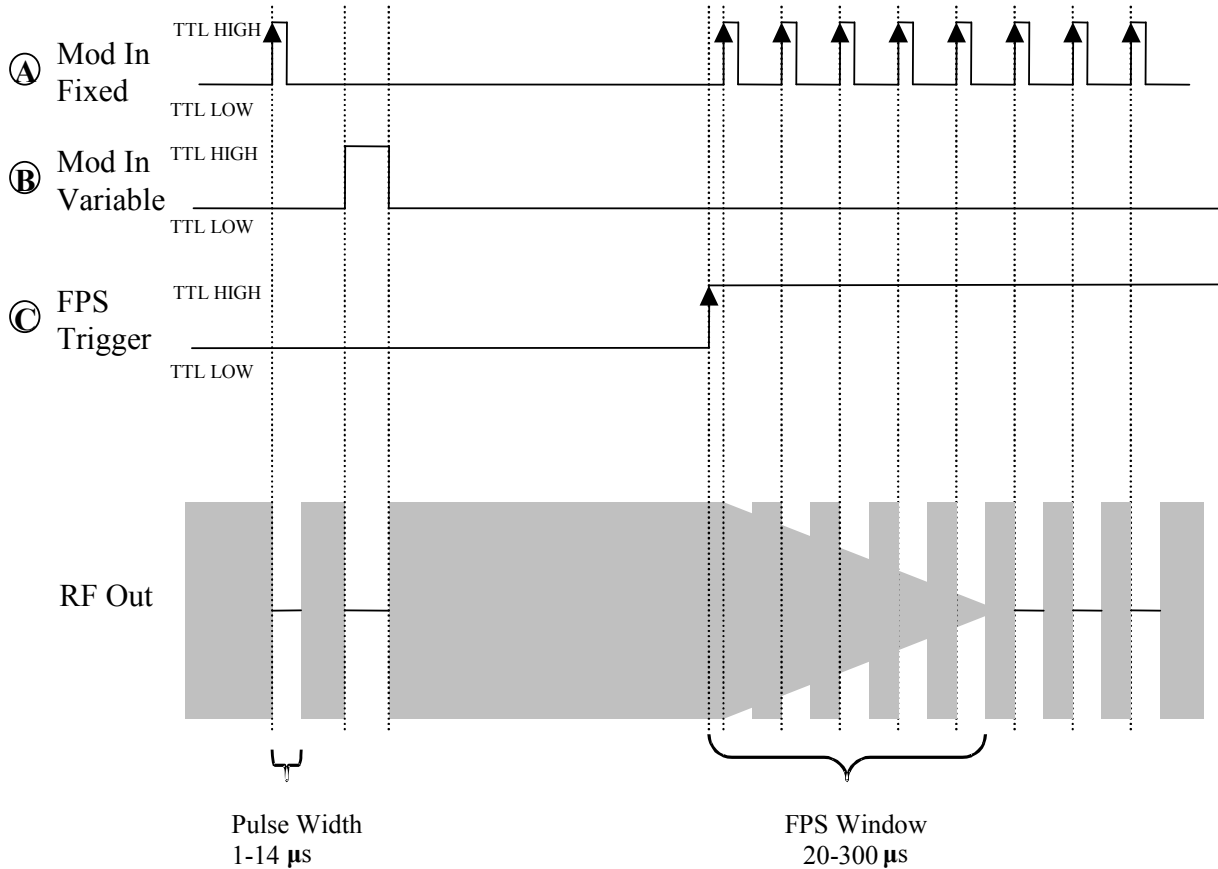
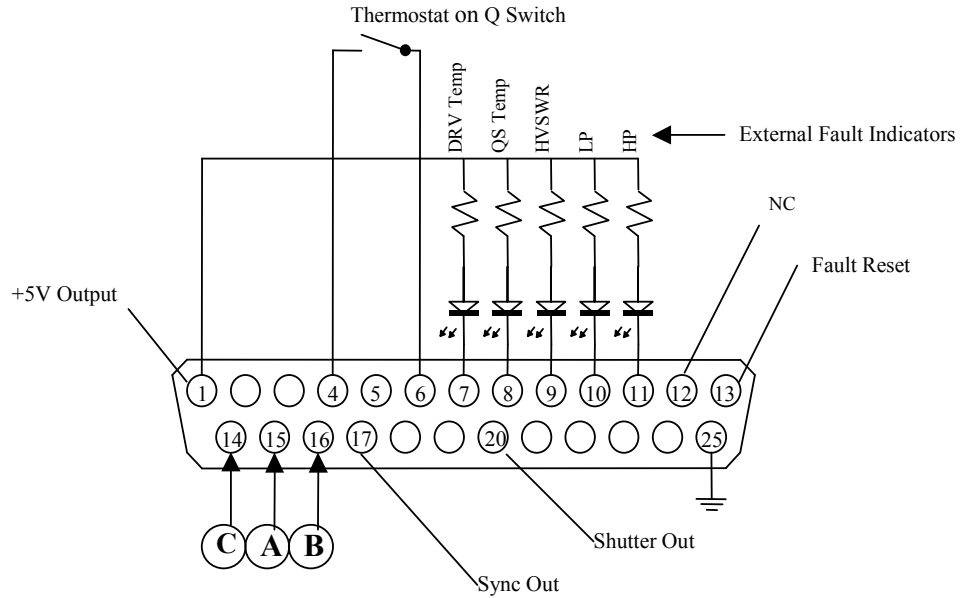

Figure 3

MQH0XX-YYDM-PPK (HIGH POWER) Pre-Pulse Kill Control
Connection and Control diagram

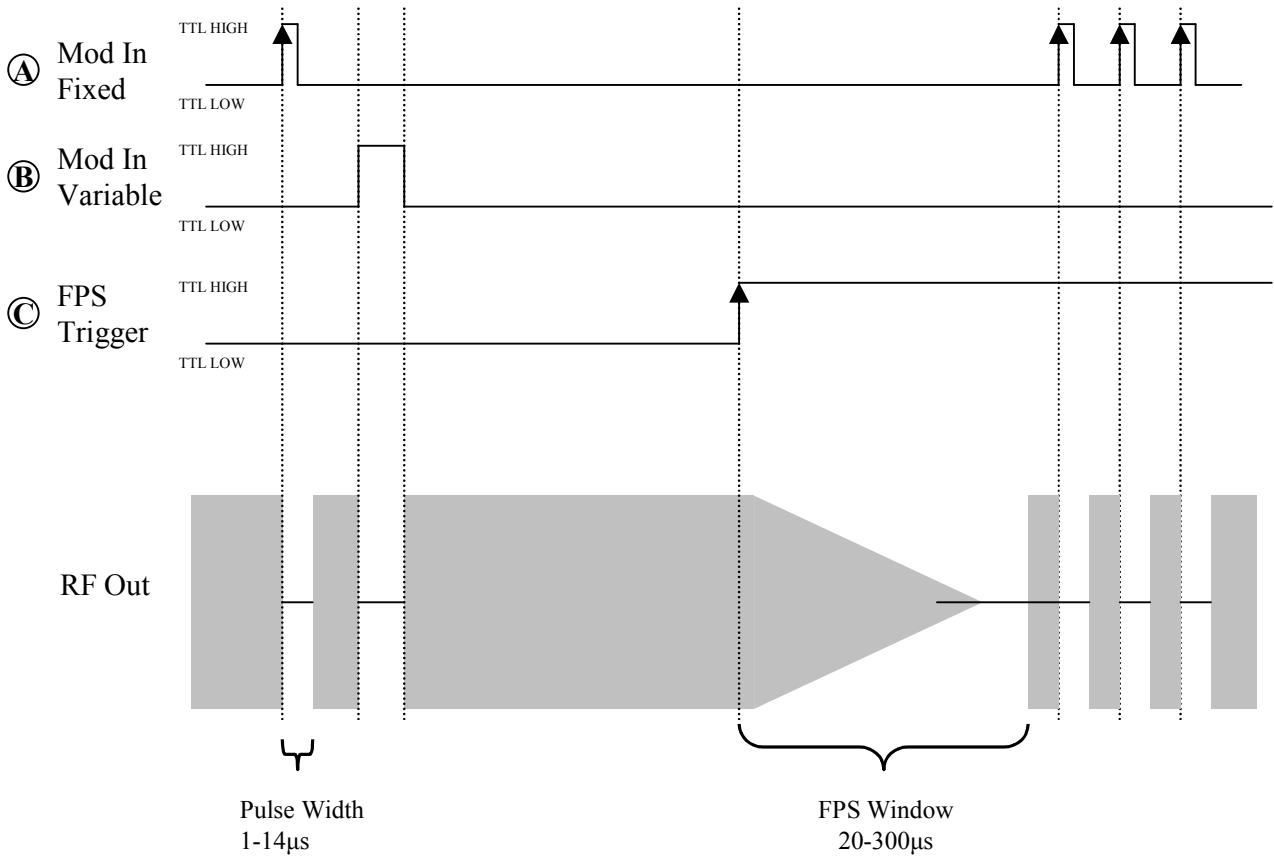
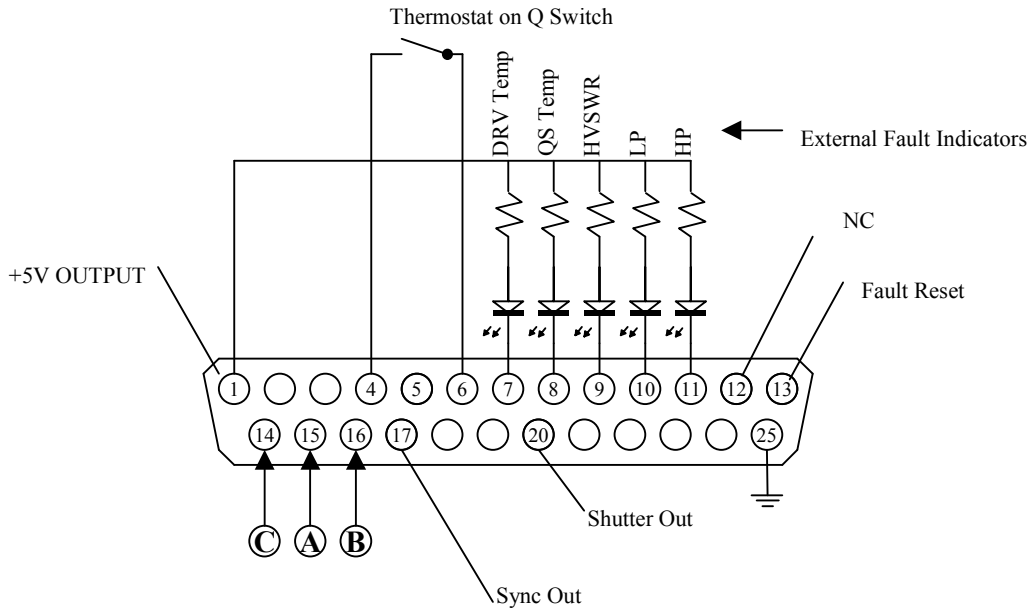

Figure 4

MQH0XX-YYDM-A05 (HIGH POWER) Analog 5 Volt Control
Connection and Control Diagrams

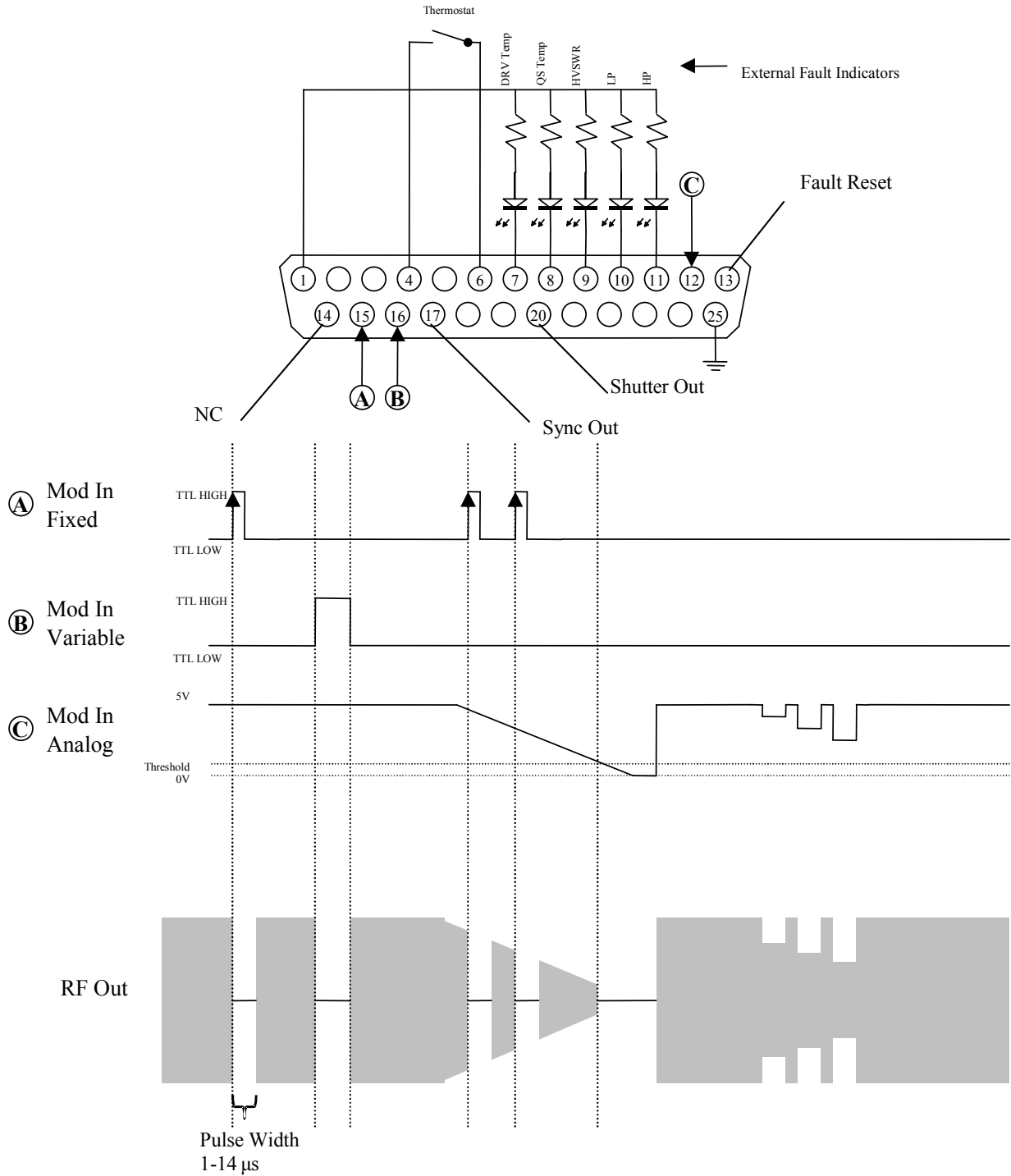

Figure 5

MQH0XX-YYDM-R05 (HIGH POWER) RF Switch to Analog 5 Volt Control
Connection and Control Diagrams

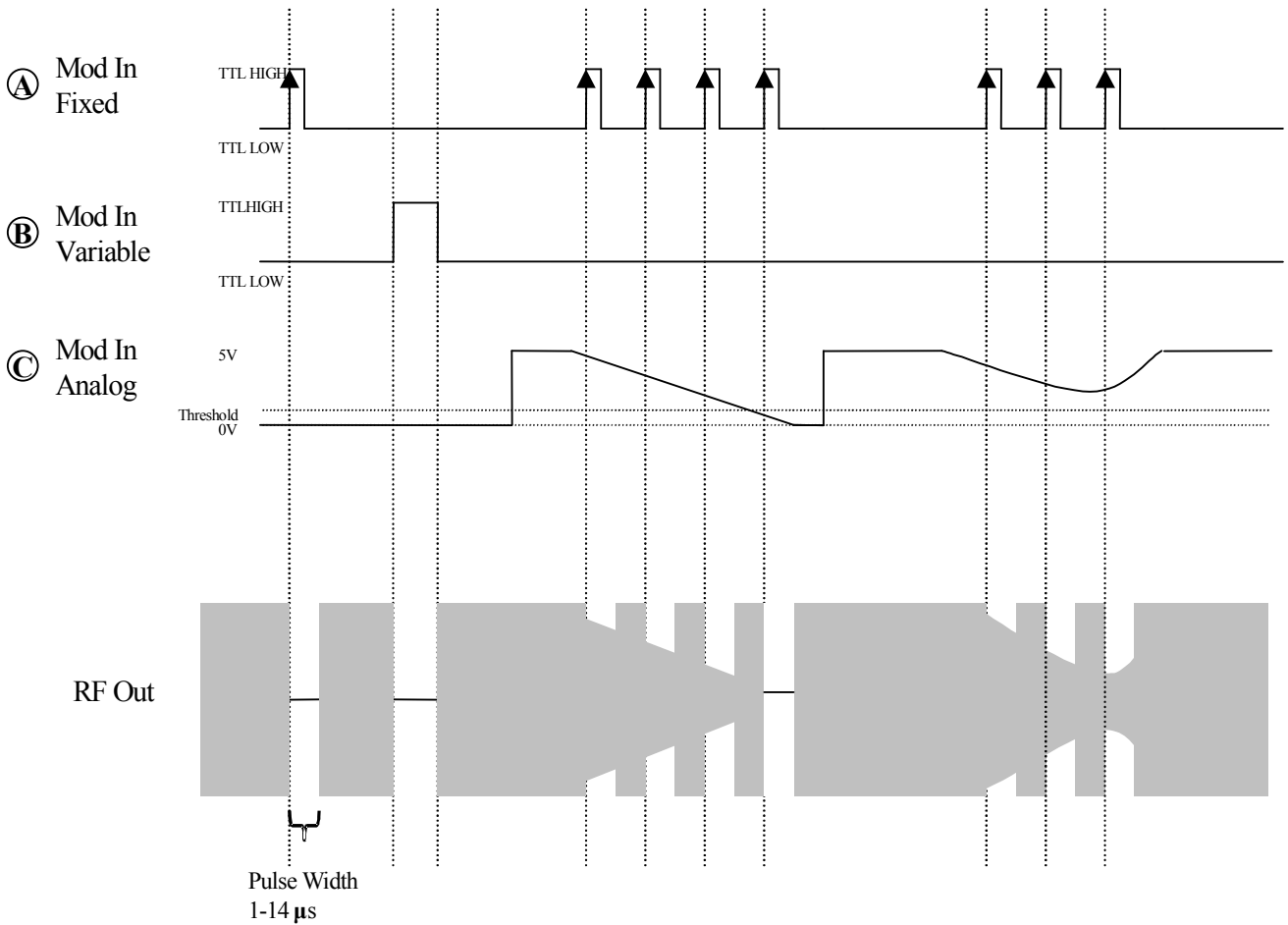
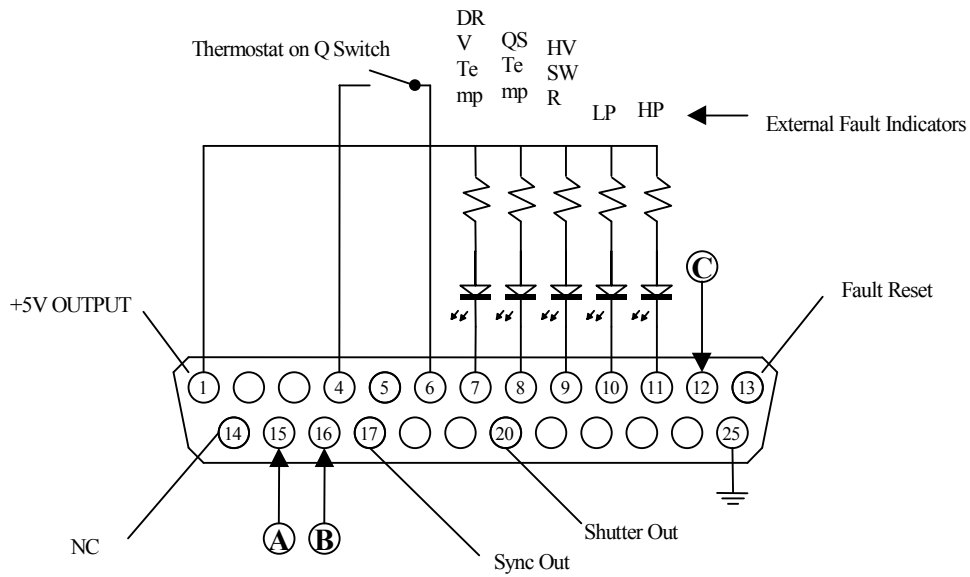
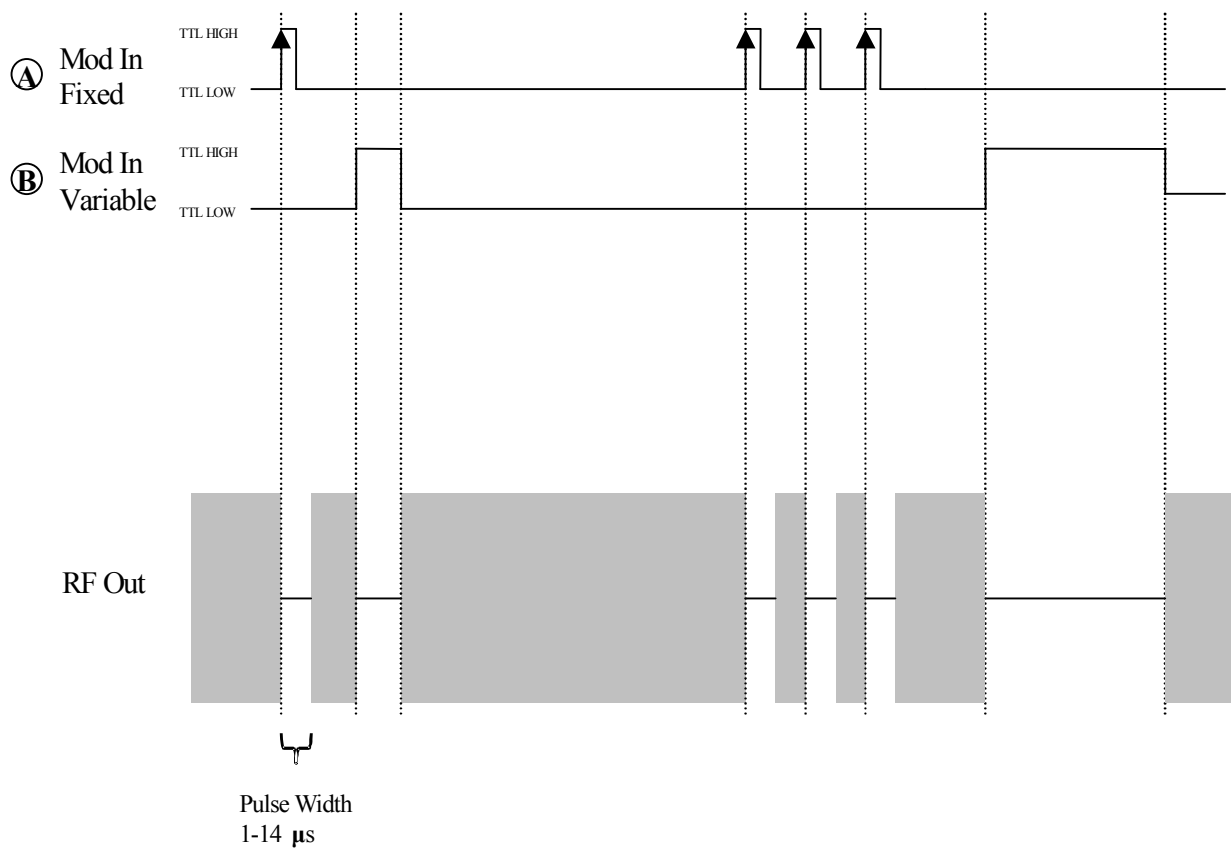
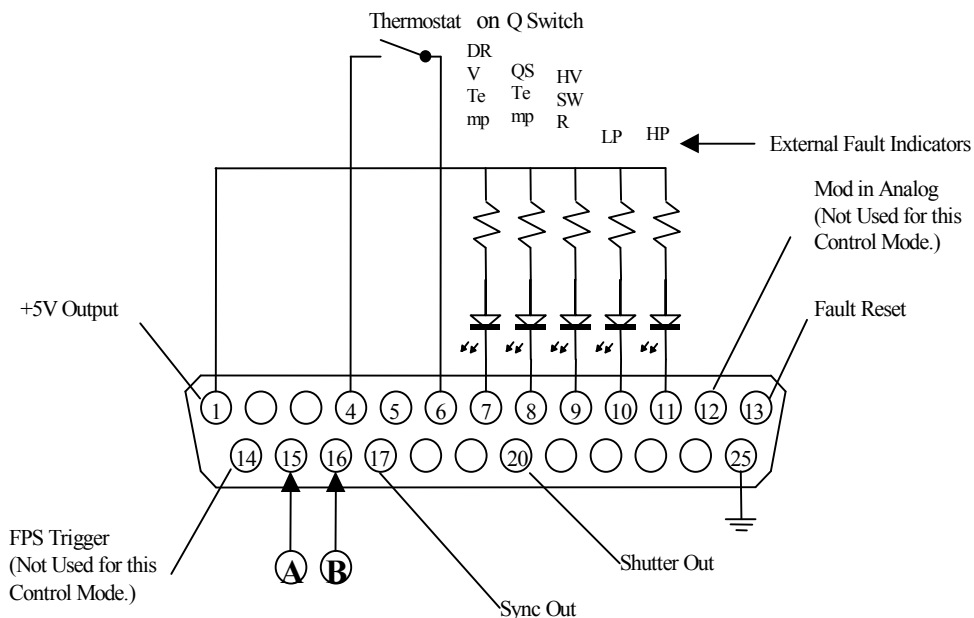

Figure 6

MQH0XX-YYDM (HIGH POWER) Digital Control Only
Connection and Control Diagrams



Ordering Codes:

Example: MQH027-100DM-A05

A 27 MHz RF Driver with two TTL Digital Modulation inputs (fixed and variable pulse width) and an analog input (A05) which enables control of the RF output power. Designed to Drive an AO Q-Switch requiring 100 watts RF Power or less. Delivered as a RoHS compliant, forced air cooled OEM Module.

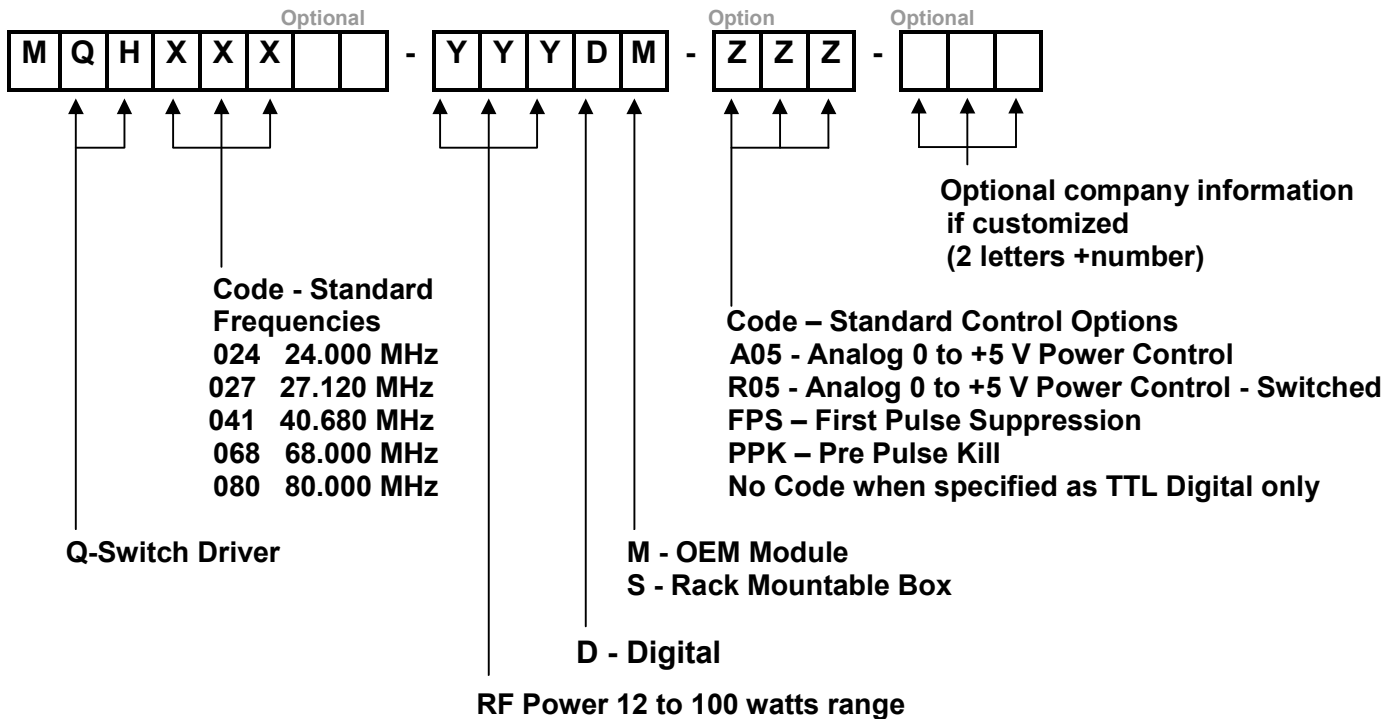
Technical Assistance & Customization

Our Engineering and Sales team are available to discuss your requirements and will assist you in selecting the most appropriate acousto-optic Q-Switch/ Driver combination for your application.