

EYP-RWL-0850-00100-1500-SOT12-0000

Version 1.00

25.11.2010

page 1 of 4

RIDGE WAVEGUIDE LASER

GaAs Semiconductor Laser Diode
Fabry-Perot Laser



General Product Information

Product	Application
850 nm Fabry-Perot Laser with hermetic TO Housing	Metrology
Monitor Diode	Sensing

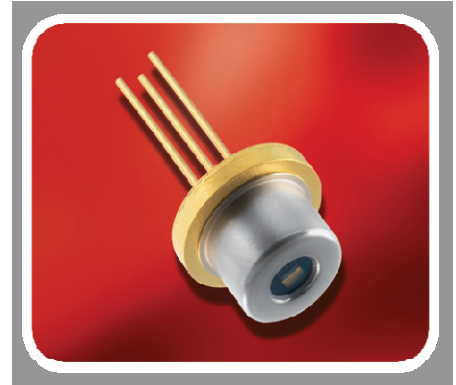

Absolute Maximum Ratings

	Symbol	Unit	min	typ	max
Storage Temperature	T_S	°C	-40		85
Operational Temperature at Case	T_C	°C	-20		50
Forward Current	I_F	mA			210
Reverse Voltage	V_R	V			0
Output Power	P_{opt}	mW			120

Stress in excess of the Absolute Maximum Ratings can cause permanent damage to the device.

Recommended Operational Conditions

	Symbol	Unit	min	typ	max
Operational Temperature at Case	T_C	°C	15		40
Forward Current	I_F	mA			200
Output Power	P_{opt}	mW			100

Measurement Conditions / Comments

Characteristics at $T_{LD} = 25\text{ °C}$ at Begin Of Life

Parameter	Symbol	Unit	min	typ	max
Center Wavelength	λ_C	nm	840	850	860
Spectral Width (FWHM)	$\Delta\lambda$	nm			1
Temperature Coefficient of Wavelength	$d\lambda / dT$	nm / K		0.3	
Output Power @ I_F : 200 mA	P_{opt}	mW	100		
Slope Efficiency	η_d	W / A	0.6	0.8	
Threshold Current	I_{th}	mA			70
Cavity Length	L	μm		1500	
Divergence parallel	$\Theta_{ }$	°		10	
Divergence perpendicular	Θ_{\perp}	°		30	

Measurement Conditions / Comments
see images on page 4
total output measured with integrating sphere
FWHM
FWHM

Distributor
amstechnologies
where technologies meet solutions

info@amstechnologies.com
www.amstechnologies-webshop.com

Contact us

EYP-RWL-0850-00100-1500-SOT12-0000

Version 1.00

25.11.2010

page 2 of 4

RIDGE WAVEGUIDE LASER

GaAs Semiconductor Laser Diode
Fabry-Perot Laser



Characteristics at T_{amb} 25 °C at Begin Of Life cont'd



Parameter	Symbol	Unit	min	typ	max
Polarization				TE	
Spatial Mode (transversal)				TEM ₀₀	
Spectral Mode (longitudinal)				Single/Multi Mode	

Measurement Conditions / Comments
E field parallel to Pin 2 - Pin 3 - plane
Fundamental Mode
depending on operating conditions

Monitor Diode



Parameter	Symbol	Unit	min	typ	max
Monitor Detector Responsivity	I_{mon} / P_{opt}	$\mu A / mW$	0.3		30
Reverse Voltage Monitor Diode	$U_{R MD}$	V	3		5

Measurement Conditions / Comments
$U_R = 5 V$

EYP-RWL-0850-00100-1500-SOT12-0000

Version 1.00 25.11.2010 page 3 of 4

RIDGE WAVEGUIDE LASER

GaAs Semiconductor Laser Diode
Fabry-Perot Laser



Package Dimensions

Parameter	Symbol	Unit	min	typ	max
Height of Emission Plane	d_{EP}	mm	3.50	3.65	3.70
Excentricity of Emission Center	R	mm			0.12
Pin Length	l_{PIN}	mm		14	

Measurement Conditions / Comments

reference plane: top side of TO header

reference: center of outer diameter of header

Package Pinout

N-Type

Case	1
Photo Diode (+)	2
Laser (-)	3

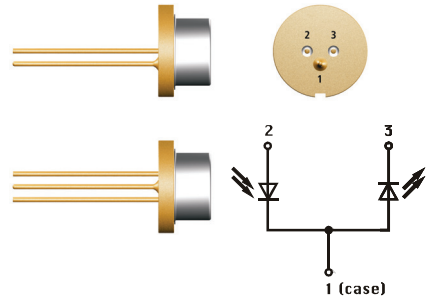

Package Drawings

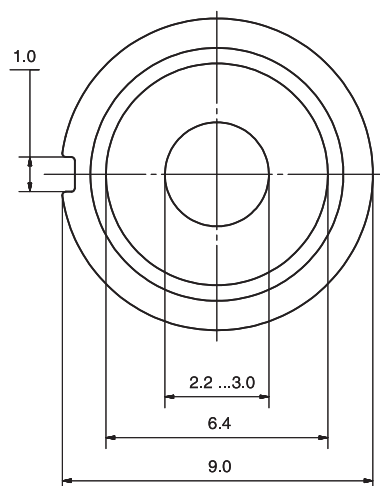
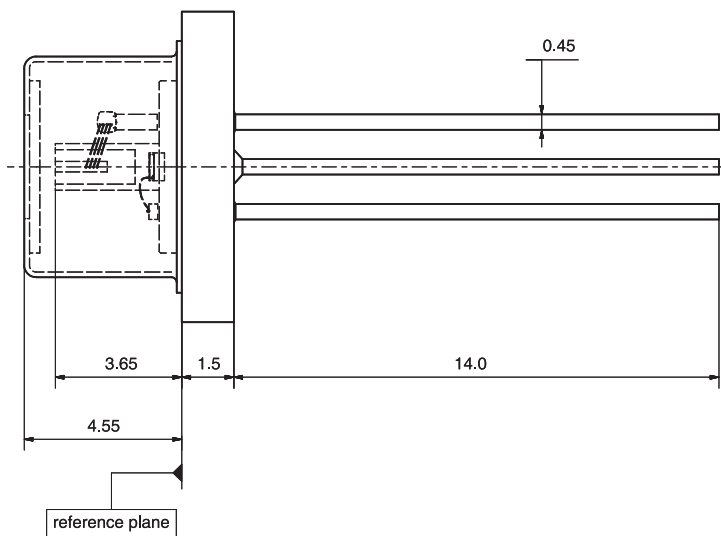

Rev 09.00

EYP-RWL-0850-00100-1500-SOT12-0000

Version 1.00

25.11.2010

page 4 of 4

RIDGE WAVEGUIDE LASER

GaAs Semiconductor Laser Diode
Fabry-Perot Laser



Typical Measurement Results

Output Power vs. Current

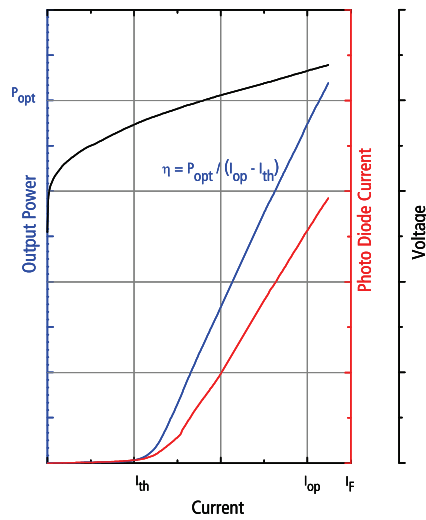

Spectra at Specified Optical Output Power

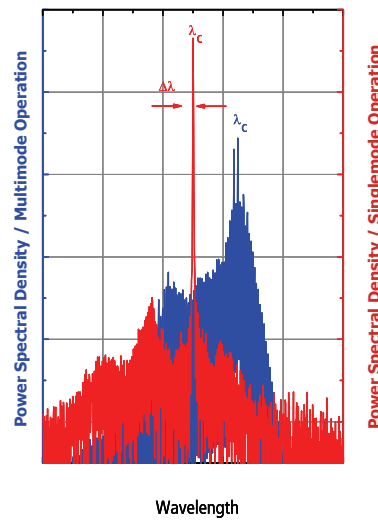

Performance figures, data and any illustrative material provided in this specification are typical and must be specifically confirmed in writing by eagleyard Photonics before they become applicable to any particular order or contract. In accordance with the eagleyard Photonics policy of continuous improvement specifications may change without notice.

Unpacking, Installation and Laser Safety

Unpacking the laser diodes should only be done at electrostatic safe workstations (EPA). Though protection against electro static discharge (ESD) is implemented in the laser package, charges may occur at surfaces. Please store this product in its original package at a dry, clean place until final use. During device installation, ESD protection has to be maintained.

The RWL diode type is known to be sensitive against thermal stress. Operating at moderate temperatures on proper heat sinks will contribute to a long lifetime of the diode.

The laser emission from this diode is close to the invisible infrared region of the electromagnetic spectrum. Avoid direct and/or indirect exposure to the free running beam. Collimating the free running beam with optics as common in optical instruments will increase threat to the human eye.

Each laser diode will come with an individual test protocol verifying the parameters given in this document.

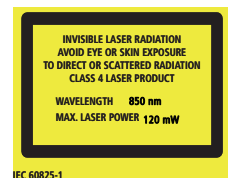
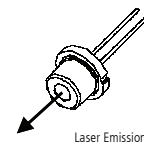

Distributor

where technologies meet solutions

info@amstechnologies.com
www.amstechnologies-webshop.com

Contact us